

Tilton rally clutch

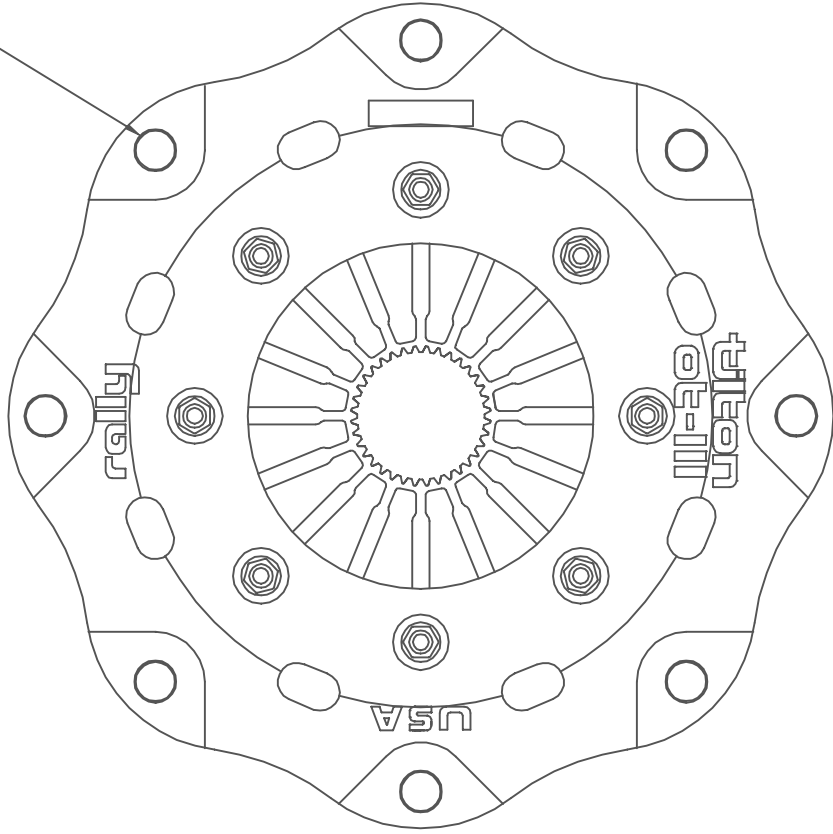
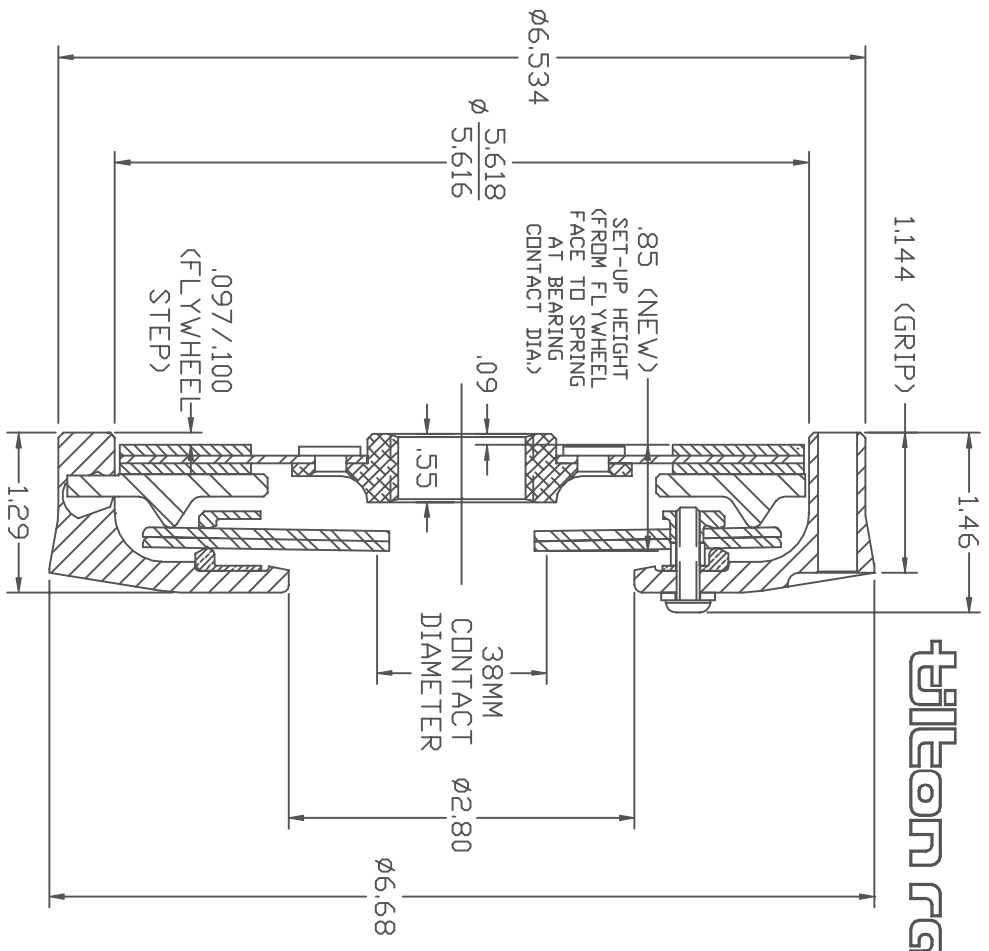

ASSEMBLY WEIGHT	4.0 LB
ASSEMBLY INERTIA	21.4 LB-IN ²
RELEASE LOAD	750 LB MAX
RELEASE TRAVEL	.16 IN
RELEASE BEARING	38mm

ILLUSTRATED WITH DISC PACK P/N 64140-7-F-36

Ø.316 THRU, 8PL,
 EQ. SP., 6.081 B.C.D.

TILTON ENGINEERING, INC.		FAX 805/688-2745	
25 EASY STREET, P.O. BOX 1787, BUELLTON, CA 93427 805/688-2353			
TITLE: 5.5" RALLY CLUTCH SINGLE PLATE		SCALE 1 : 1 DWG 4022	
DRAWN BY WAHL	CHKD ONEIL	DATE 6/13/00	SHEET 1 OF 1
P/N 67-301HG			

This document contains proprietary information of TILTON ENGINEERING, INC., and its receipt or possession does not convey the rights to reproduce, disclose its contents, or to manufacture, use or sell anything it may describe. Reproduction, disclosure, or use without specific written authorization of TILTON ENGINEERING INC. is strictly forbidden.